



**ERHARD
VALVES**

TWIN-AIR[®]
Air Valves



TWIN-AIR® Air Valves

for automatic air release and air admission of pipelines

TWIN-AIR® Air Valves are installed at the high points of closed conduits and downstream or upstream of valves.

They may be used for pipe burst control valves, behind throttling points and feeding pumps or turbines.

Air Valves are needed for preventing troublesome air accumulations in the pipelines, supporting complete filling and emptying of a pipeline, limiting depression and evacuating gases (air) accumulated during operation under pressure.

Mode of operation

When the pipeline is empty and pressureless, both orifices of the TWIN-AIR® Air Valve are open.

Filling the pipeline

When filling the pipeline with water, the air is pushed in front

of the water column and can freely discharge through the large and the small orifice of the Air Valve. When during the filling process the water column reaches the float point of both balls, they are raised with the rising liquid level. The large orifice is now closed by the large float ball. At the same time, the small float ball activates a lever mechanism closing the small orifice by means of a rubber plug.

Air evacuation under pressure

When under full working pressure the liquid level descends due to air accumulation, the small float ball drops reaching the float point, and releases the small air-exhausting cross section.

At each operating cycle, the small orifice is cleaned by means

of a patented cleaning device, a pin being moved upwards by the air blown off and being pushed back by spring force after completion of the air-evacuation process. Due to the acting differential pressure the large ball closes the large orifice when evacuating air during operation.

Emptying the pipeline

When during operation, the pipeline pressure decreases to or below atmospheric pressure, the two float balls fall and release the air outflow and inflow cross sections.

Now, the ambient air can flow through the Air Valve into the pipeline according to the depression prevailing in the pipeline.

Irresistible design features

Convincing details

- ⇒ Compact design.
- ⇒ Streamlined.
- ⇒ Lightweight type.
- ⇒ Safe operation.
- ⇒ Little maintenance.
- ⇒ Large air outflow and inflow cross sections.
- ⇒ For maximum air outflow and inflow velocities.
- ⇒ Automatic air release under operating conditions, lever-operated, bore Ø 2.5 mm, with patented self-cleaning feature effective at each operating cycle.
- ⇒ Large orifice with connecting thread.
- ⇒ Effective corrosion protection.
- ⇒ Enclosed seal.
- ⇒ Pressure rating up to PN 25.
- ⇒ No copper alloy.
- ⇒ Self-centering float ball.
- ⇒ High-grade materials.



Materials and corrosion protection

- ⇒ Body and body cover of ductile cast iron SG GGG-50.
- ⇒ Body inside: **VITREOUS ENAMEL**.
- ⇒ Body outside: **EKB** epoxy coating.
- ⇒ Body cover: inside and outside **EKB** epoxy coating.
- ⇒ Float ball for DN 50 to DN 100 of multichamber GRP.
- ⇒ Float ball for DN 150 and DN 200 of austenitic CrNi steel (mat. No. 1.4571).
- ⇒ Float guide and float assembly for evacuation under pressure of austenitic CrNi steel (mat. 1.4571).
- ⇒ Body seat of EPDM.
- ⇒ Connecting bolts of stainless steel A4.

TWIN-AIR® Air Valves

for automatic air release and air admission of pipelines

Range of application

- ⇒ Automatic air release and air admission of pipelines for potable water.
- ⇒ Special designs on request, e. g. with protective screen, with suppressed air-inflow feature, etc.

Operating conditions

- ⇒ Min. working pressure: 0.2 bar.
- ⇒ Max. working pressure: up to 25 bars.
- ⇒ Max. working temperature: 70°C.

Prod. No., pressure ratings, flanges

Prod. No.	Size DN	Pressure rating PN	Hydrost. test pressure in bars for body	Hydrost. test pressure in bars for seat	Design dimensions of the flanges
6937 7200	50-200	25	37,5	0,2/25	DIN 28606 PN 25
6927 7200	100-200	16	24,0	0,2/16	DIN 28605 PN 16
6917 7200	200	10	15,0	0,2/10	DIN 28604 PN 10

Detail: Air evacuation under pressure with patented cleaning device

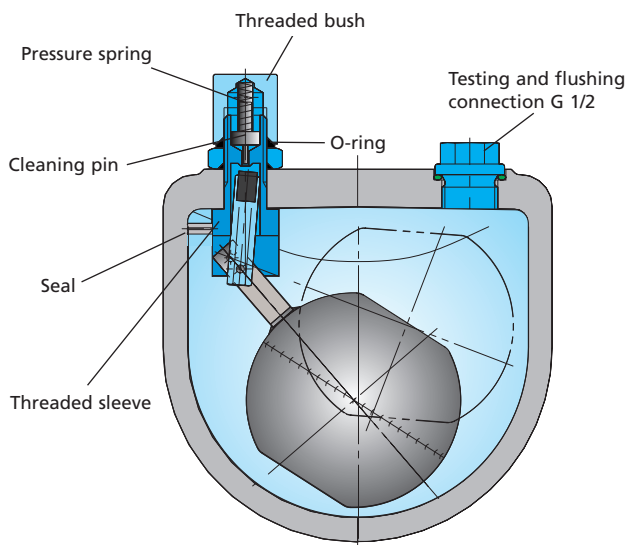

Recommended installation: TWIN-AIR® Air Valve with Isolating Short Body Multimed Gate Valve

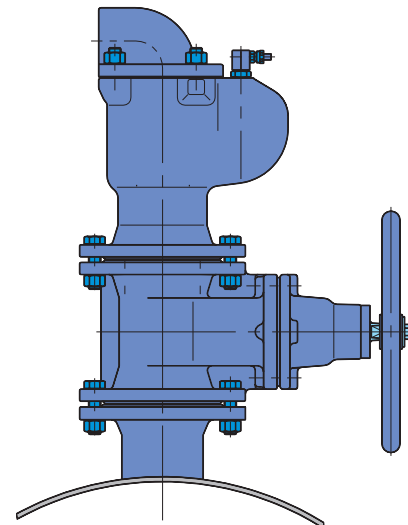

Dimensions and weights

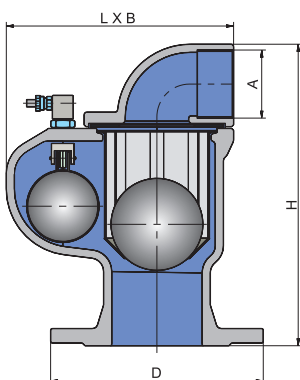

Size DN	Height H mm	Flange Ø D			Ext. dimensions length x width L x B mm	Orifice cross section mm ²		Thread-connection A	Weight appr. kg	Volume m ³
		PN10	PN25	PN16		large orif.	small orif.			
50	317	165	165	165	240 x 191	3850	5	G 2½	19	0.015
80	317	200	200	200	240 x 191	3850	5	G 2½	19	0.015
100	333	235	220	220	240 x 191	3850	5	G 2½	20	0.015
150	385	300	285	285	316 x 222	9500	5	G 4	32	0.029
200	385	360	340	340	316 x 222	9500	5	G 4	43	0.029

Air outflow and inflow capacities

The suitable valve size is selected on the basis of the actual working conditions.

Air capacity

For air capacities, see below diagrams:

- 1 Air evacuation via the large orifice (filling the pipeline). The air flow rate Q is identical with the inflowing water rate.
- 2 Air evacuation via the small orifice (under working pressure).

- 3 Air admission via the large orifice (emptying the pipeline). The air flow rate Q is identical with the outflowing water rate.

Extreme air rate demand

If one single air valve cannot comply with the specified outflow and inflow requirements, air valves can be fitted in clusters.

For large air inflow rates (valves larger than DN 200), **ERHARD** Disc Type Air Inlet Valves are the appropriate solution.

Recommended limit values

Filling the pipeline

During the closing process of the *TWIN-AIR*® Air Valve, for safety reasons the max. admissible water hammer should not exceed $P = 3$ bars. This is based on filling the pipeline at a velocity of 0.25 m/sec.

Recommended limit values

Emptying the pipeline

The recommended air velocity when emptying the pipeline is $V_{max.} = 80$ m/sec. (referred to the clear air-inflow cross section).

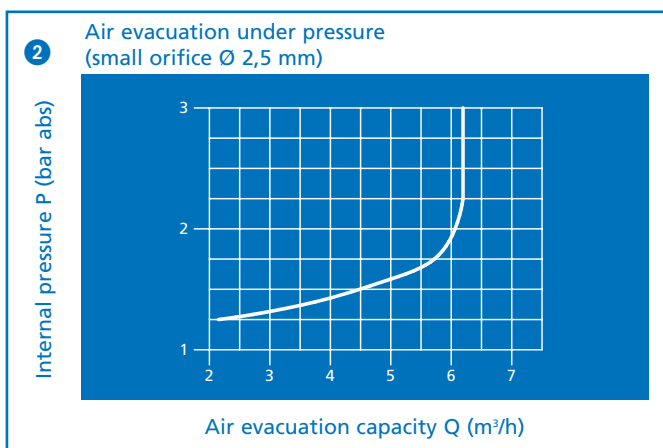
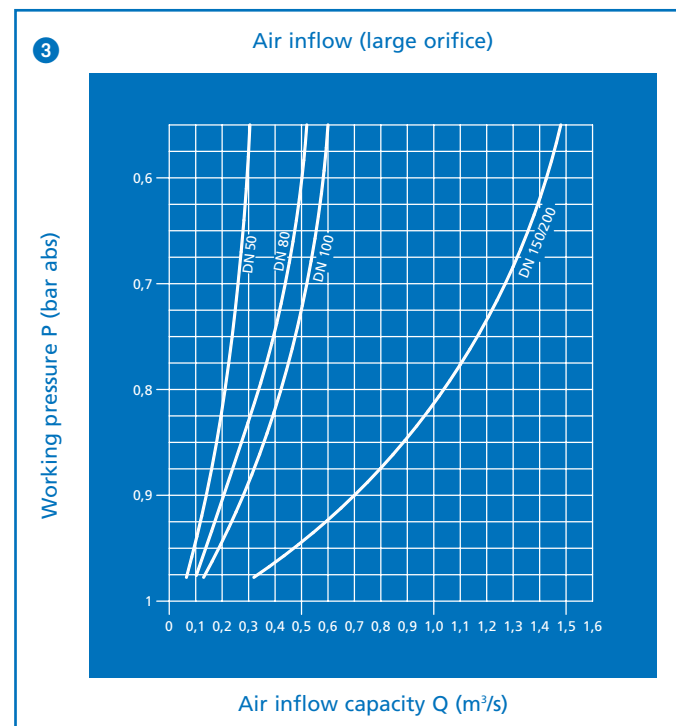
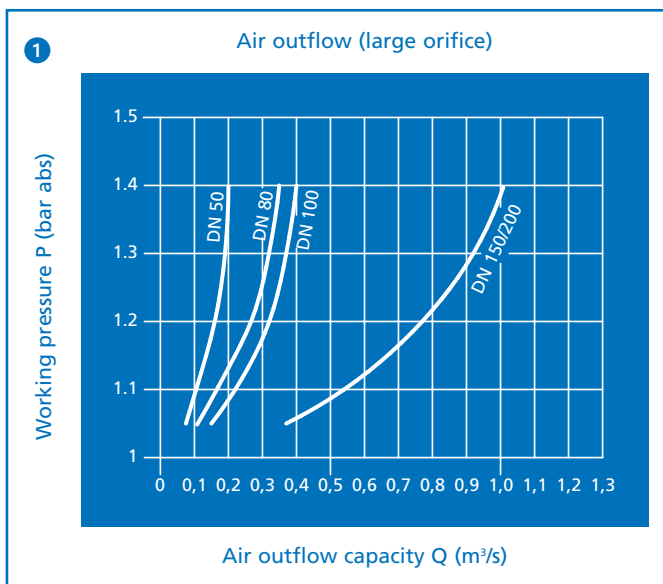

Postfach 1280 · D-89502 Heidenheim
 Phone: +49(0)7321 320-0 · Fax: +49(0)7321 320-525
<http://www.erhard.de>
 e-mail: export@erhard.de

Data corresponding to the latest level of development, modifications reserved.
 Printed in Germany. 04/05

